

EPD-053, EPD-053M

5.65" Wireless ePaper Display Module & Device

NEW

EPD-053 Device



EPD-053M

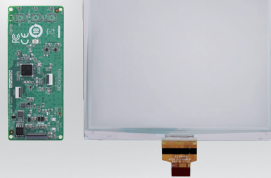

Features

- ARM Cortex-M3 Core Processor
- Supported IEEE 802.15.4 / 2.4 G Networks
- 5.65" ePaper Panel Display
- Great for Low Power Consumption
- Multiple I/O Control with One Button & Two Colors for LED
- Supported Temperature Range: 0 ~ 40 °C
- High Performance Integrated System with RTOS
- Supports Over-the-Air Upgrades (OTA)
- Solution with WISE-3610Z/WISE-3240 Network Coordinator & ARK ePaper Manager Server

Introduction

EPD-053 supports the ultra-low power 2.4GHz RF wireless protocol integrated with 5.65" EPD in ARM Cortex-M3 processor. The module can support hospital, pharmacy, factory, warehouse and retail applications. With optimization on the power consumption and device management, your applications with low data rate requirements can achieve years long battery lifetimes across thousands of devices connections.

The Advantech EPD-053 provides multiple interfaces for application control which are highly integrated with the EPD driver and low power consumption system. EPD-053 can auto-join the network group with the WISE-3240 IoT Router and WISE-3610Z IoT Gateway. Data can be easily acquired and transformed into a different format to communicate with the ePaper Manager Server. System integrators can focus on application development and system management.

Specifications

Computing System	MCU	TI 32-bit ARM Cortex-M3 Processor
	Memory	RAM 28KB
Display	Screen Size	125.4 x 99.5 mm
	Resolution	600 x 448 pixels
Storage	Internal	Flash: 128 KB
	External	SPI Flash: 512 KB
Network	Standard	IEEE 802.15.4
	Frequency Band	2.4-GHz
	Channels	11-26
	Channel Separation	5MHz
	Transmit Power	-21dBm~ +5dBm
	Receiver Sensitivity	-100dBm
	RF Data Rate	250 Kbps
	Function	End node
	Antenna Connector	MHF Connector
Antenna	FPC Antenna Antenna	
Interface		LED x1
		Function Key x1
Power	Battery	CR2450 x4 (2480mAh)
Environment	Operational Temperature	0 ~ 40 °C
	Non-Operational Temp.	-25 ~ 60 °C
	Operating Humidity	5 ~ 80% Relative Humidity, non-condensing
Physical Characteristics	Dimensions (W x H)	125.4 x 99.5 mm
	Weight	0.165KG with housing and battery
Operating System		RTOS

* Note:

- The channel frequency selection can be supported by further plan.
- EPD Data Report and Wakeup behavior duration can be adjusted by different scenario from RESTful API
- System bundles wireless modules; which need RED compliance

Board Diagram

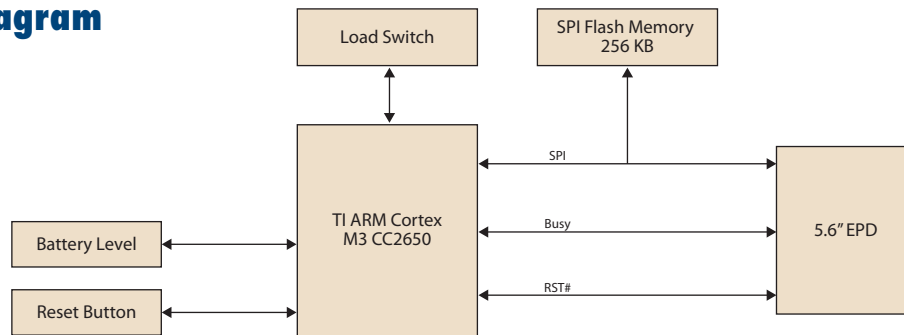

Dimensions

EPD-053M ePaper Module

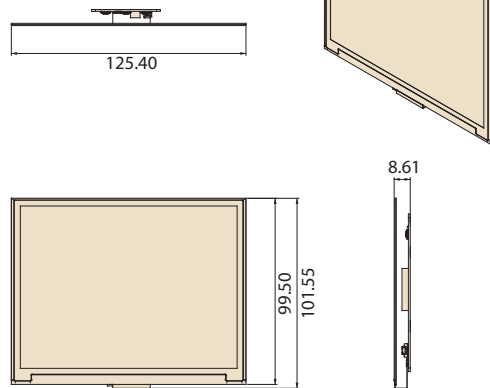

EPD-053 Device

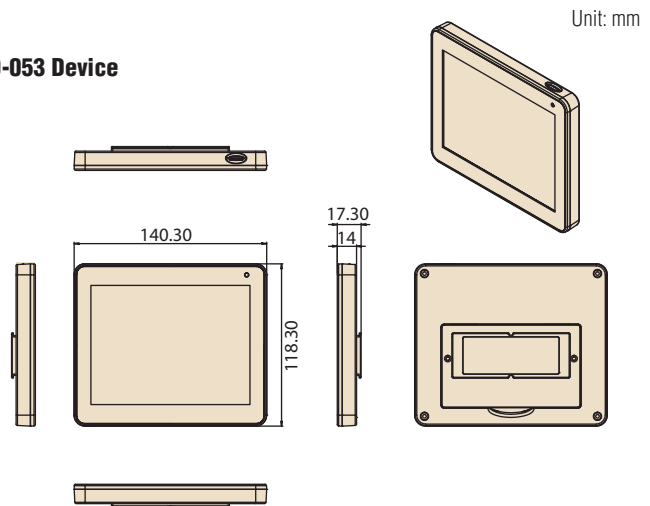

Unit: mm

Ordering Information

Part No.	Description
EPD-053R1AG-NTC02	5.65" Wireless ePaper display module in 2.4G
EPD-053R2AG-NTC02	5.65" Wireless ePaper display device solution in 2.4G
EPD-053R2AG-NTC12	EPD-053R2AG-NTC02 for 20 pcs device solution kit

Optional Accessories

Part No.	Description
1760002692-01	4 pcs CR2450 battery
9696053RS00	Switch_LED daughter board
1700015038	FPC Cable 10P-0.5mm 7.9cm for DCU2.0

Windows development kit ordering information

	Part No.	Description
EPD device	EPD-053R2AG-NTC02	5.65" Wireless ePaper display device solution in 2.4G
	WISE-3610ZOS-41B1E	Gateway for EU
Gateway	WISE-3610ZOS-41B1J	Gateway for Japan
	WISE-3610ZOS-41B1N	Gateway for NA
	WISE-3610ZOS-41B1T	Gateway for Taiwan
	WISE-3610ZOS-41B1C	Gateway for China
ePaper manager	ARK-1123H-EP1A2 for Entry	Windows/1T HD/8G RAM and build in ePaper Manager Software with 500 device licenses
	ARK-2250L-EP1A1 for Enterprise	

Packing List

Model Name	Part No.	Description
EPD-053	EPD-053R1AG-NTC02	1. 5.6" Red/Black/White ePaper
		2. ePaper Control Board with IEEE802.15.4 (2.4G) wireless control module
EPD-053	EPD-053R2AG-NTC02	5.6" Red/Black/White ePaper IEEE802.15.4 (2.4G) device solution

- * All E Ink Panel inspection criteria refer to E Ink CAS & Inspection standard documents.
- * Note: E Ink Recommend condition for storage:
Temperature: 20 +/-10 degree C
Humidity : 60% RH+-10%RH, Non-condensing
- * Note: If panel module have been put in low temperature between 0--25 degree C for a while, we recommend to leave it between 20 to 30 degree C for 4 days before assembly.

Ubuntu development kit ordering information

	Part No.	Description
EPD device	EPD-053R2AG-NTC02	5.65" Wireless ePaper display device solution in 2.4G
	WISE-3240IOS-41A1E	Router for EU
Router	WISE-3240IOS-41A1J	Router for Japan
	WISE-3240IOS-41A1N	Router for NA
	WISE-3240IOS-41A1T	Router for Taiwan
	WISE-3240IOS-41A1C	Router for China
ePaper manager	ARK-1123H-EP2A2 for Entry	Ubuntu /1T HD/8G RAM and build in ePaper Manager Software with 500 device licenses
	ARK-2250L-EP1A2 for Enterprise	